

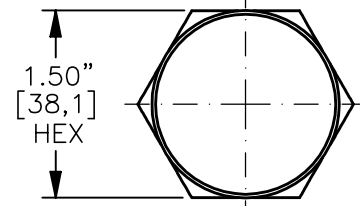

### 3-WAY DIRECTIONAL CONTROL VALVE SPOOL TYPE, PILOT OPERATED, SPOOL "A".

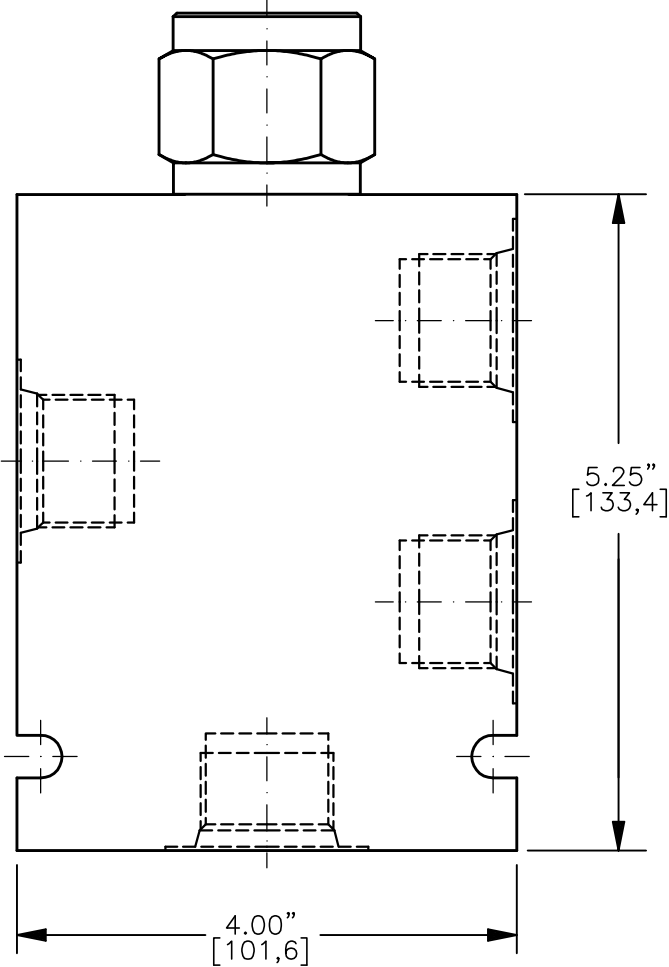

TORQUE to 95/100 Ft-Lb  
[127/135 N-m]

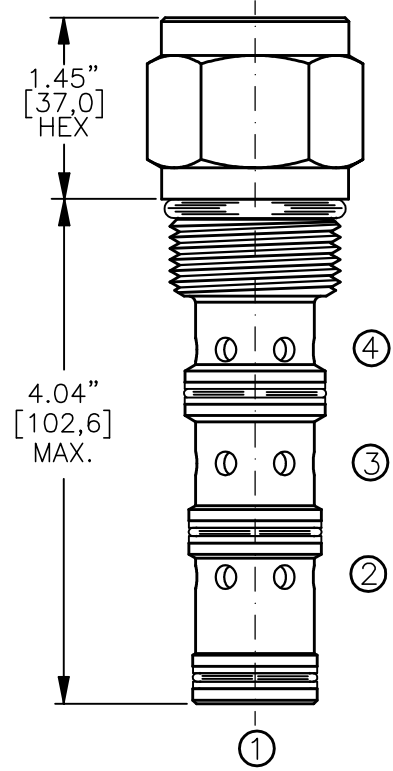

FOR ALUMINUM OR STEEL VALVE HOUSING CONFIGURATIONS SEE PAGE 0-044.1

#### DCPS-16-X-A-F-0-XXX

- BASIC
- SIZE  
16 = 1.312"-12 UNF
- SEALS  
N = BUNA "N"  
V = VITON
- SPOOL  
"A" = SPOOL
- ADJUSTMENT  
F = FIXED (FACTORY SET)

- PRESSURE BIAS SPRING
- 060 = 60 PSI (FIXED)
- 120 = 120 PSI (FIXED)
- 160 = 160 PSI (FIXED)

- PORTS
- 0 = CARTRIDGE ONLY
- 06BX = G 3/4" BSPP
- 08BX = G 1" BSPP
- 12TX = SAE - #12
- 16TX = SAE - #16
- "A" - ALUM. HOUSING
- "S" - STEEL HOUSING

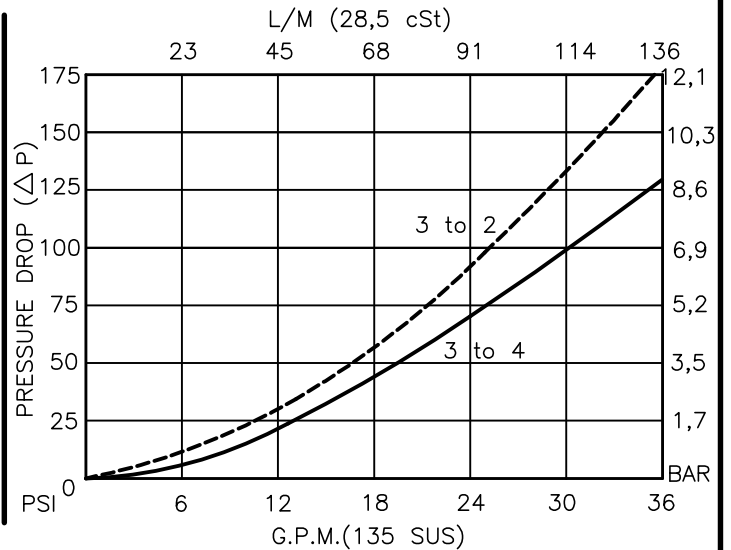



## 3-WAY DIRECTIONAL CONTROL VALVE SPOOL TYPE, PILOT OPERATED, SPOOL "A".

### DESCRIPTION

This unit is a DIRECT ACTING, SCREW IN CARTRIDGE STYLE, SPOOL TYPE, HYDRAULIC 3-WAY DIRECTIONAL CONTROL ELEMENT, requiring remote pilot actuation.

### OPERATIONS

This valve allows flow from port 3 to port 2 with a spring biased spool. Port 4 is blocked. The spool will shift when piloted at port 1 with sufficient pressure to overcome the spring bias and allow flow from port 3 to port 4. Spring is vented to port 4. This valve shifts in an open center position.

### FEATURES AND BENEFITS

Leakproof fixed type.

This valve has a fixed bias spring.

Overset protection – spring can not go solid.

Hardened precision fitted spool & cage provides reliable, long life.

A unibody cage construction provides very low hysteresis and reliable operation.

All external carbon steel parts are plated for longer life against the elements.

Valve is available in fixed type.

All cartridge valves are 100% functionally tested.

Industry common cavity.

### SPECIFICATIONS

OPERATING PRESSURE: 5,000 PSI [350 Bar]

PROOF PRESSURE: 10,000 PSI [700 Bar]

FLOW: 36.0 GPM [136,0 L/M] nominal. See performance chart.

INTERNAL LEAKAGE: 5 cu.in./min. [85 cc/m].

DEFINITION OF CRACK: evident at 0.06 GPM [0.25 LPM]

VALVE HOUSINGS: 2500 PSI [175 Bar] = Aluminum – Anodized.

5000 PSI [350 Bar] = Steel – Unplated.

OPERATING TEMPERATURE: -40° to +250° F. [-40° to +120° C.]

OPERATING MEDIA: All general purpose hydraulic fluids such as MIL-H-5606, SAE-#10, SAE-#20, etc.

INSTALLATION: No restriction.

FILTRATION: 25 microns or better.

SEAL KIT NUMBER: SKN-1642 for buna "N".

SKV-1642 for viton.

WEIGHT: 1.5 lb [0,68 kg] cartridge only.

VALVE CAVITY: #C1640, See Page 0-044.0.